

PRORIL

50 Hz

Designed for light weight, excellent performance, low energy consumption, and easy maintenance, PRORIL submersible handy pumps serve a wide range of pumping applications on utility, construction, industrial, and municipal job sites.

Handy and Residue Pump

SMART VOX

750

Handy Pump



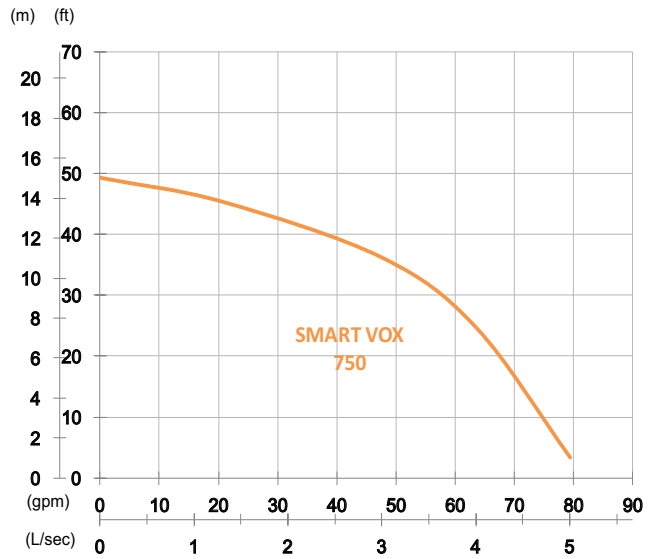

Shaft Speed : 2850 rpm

Outlet : 50mm, 2in

OUTPUT	HEAD	FLOW
0.75 kW	Rated : 11m, 36ft	Rated : 3 L/s, 48 gpm
1 HP	Max : 15m, 49ft	Max : 5 L/s, 79 gpm

Solid Passage : 7 mm, 0.3 in

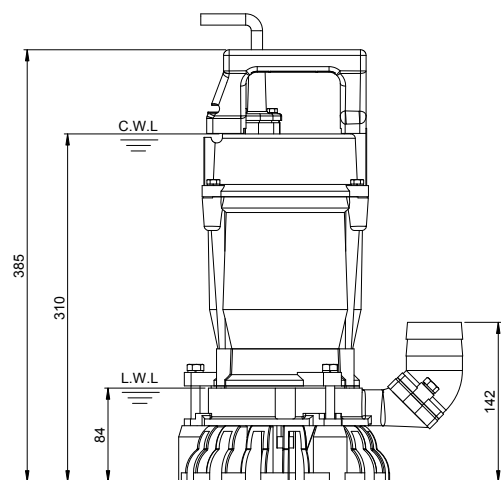
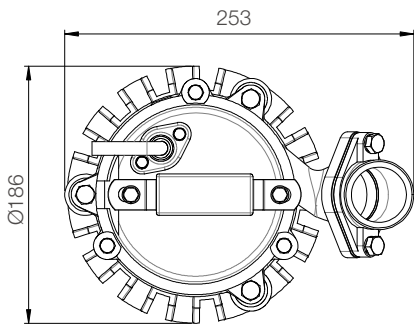

unit : mm

Weight : 13kg / 29 lbs

Pump Type	Electric Submersible Pumps	
	1-Phase	
Motor	Type	Induction Motor
	Poles	2 Pole
	Insulation	Class F
	Protector	Miniature Thermal Protector
	Starter	Capacitor-Run
Lubricant	Food Grade (ISO VG32)	
Impeller Type	Semi-Vortex	
Shaft Seal	Double Mechanical Seal	
	Silicon Carbide VS Ceramic / Carbon	
Bearings	C3 Shielded ball bearings	
Cable	PVC (CSA Certified) / H07RN-F	
	6m (20ft) or longer upon request.	
Materials	Pump Casing	Gray Iron
	Impeller	Synthetic Polymers
	Motor Frame	Aluminum
	Motor Shaft	Stainless Steel
	Agitator	Stainless Steel
	Strainer	Synthetic Polymers
Max. Liquid Temperature	40°C (104°F)	
Max. Submersion Depth	20m (66ft)	
pH Range	pH 5 - pH 8	